



Almo II with exchanger

Equipment sheet
Fireplace stove with exchanger

GB

Introduction

We thank you very much for purchasing our product!

The description of the heating device will inform you in detail about the design, technical specification and operation of the heating device. We recommend you to acquaint yourselves closely with these data. In this way, you will avoid possible faults during the proper assembly and operation.

You will find detailed conditions of installation and operation in General Manual of Operation (included in the scope of the delivery).

Notes in the text

GB



Of utmost importance there are the notes entitled **WARNING**. The notes entitled **WARNING** advise you on **serious danger of damage to the heating device or of an injury**.



The note entitled **Notice** advises you on possible damage to your heating device.



The note entitled **Important** calls your attention to the information important for the operation of your heating device.



The note itself calls your attention to the information important for the operation of your heating device in general.

Contents

1. Technical data	1
2. Technical description	2
3. List of spare parts	3
3.1. Overall scheme of the model	3
3.2. Detail A1	5
3.3. Detail A2, A3, A4, A5.....	7
4. Dimensioned diagram	9
4.1. Connection of the exchanger	9
5. Easy control	10
6. Ignition flap	11
7. Installation of the coolant loop	12
8. Instructions for cleaning of the exchanger	13

1. Technical data

Suitable fuel:

As concerns suitable fuel to be employed, see the chapter **2.2 Fuel** in the General Manual of Operation.

Proper operation:

As concerns the proper and safe operation of the fireplace stove, see the chapters **2. Description of the combustion process** and **5. Operating instructions** in the General Manual of Operation.

Instructions for the control of combustion process

Fuel		Output of the heating device	Quantity of fuel	Primary air	Secondary air	Tertiary air
Blockwood		100%	3,1 kg/hour		Easy control 100%	
		33%	1 kg/hour		Easy control 50%	

Technical data

	Blockwood
Achieved heat output (100%)	10,2 kW
Nominal heat output	10,2 kW
Reduced heat output (33%)	—
Output delivered by the stove body only	2,4 kW
Output available for heating of water	7,8 kW
Maximum stoking amount of the fuel	3,1 kg/hour
Average temperature of combustion products behind the smoke flue neck	302 °C
Maximum mass flow of dry combustion products	9,2 g/s
Energy efficiency	78,9 %
Average concentration of CO ₂	9,76 %
Concentration of CO in combustion products at 13% O ₂	692 mg/Nm ³
Average concentration of dust at 13% O ₂	37 mg/Nm ³
The amount of combustion air at nominal output	26 m ³ /hour
Tested in compliance with EN 13 240	

Technical information

Height	983 mm
Width	492 mm
Depth	527 mm
Weight	143 kg
Diameter of the smoke flue	150 mm
Maximum operating over-pressure of the exchanger	0,2 MPa
Water contents of the exchanger	14 l
Recommended heat gradient (t _{output} – t _{input})	75 – 60 °C
Min. chimney stack draught in the smoke flue neck	12 Pa
Heating capacity (middle heat losses) at 10,2 kW	cca 184 m ³
Controllable output	3,3 – 10,2 kW

2. Technical description

Technical description

GB

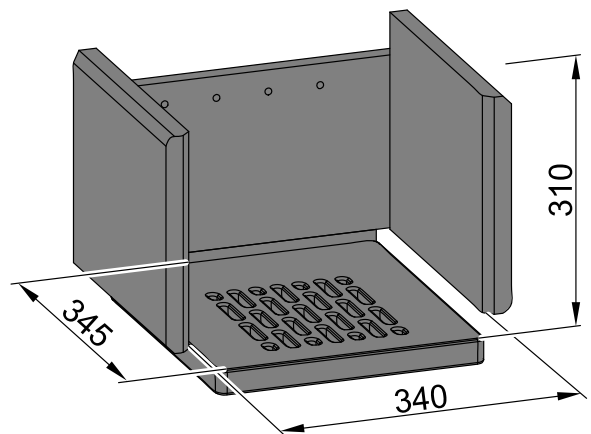
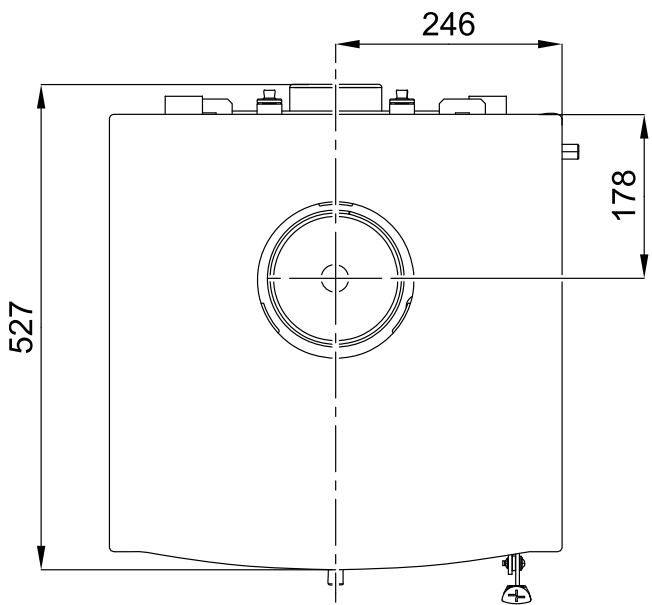
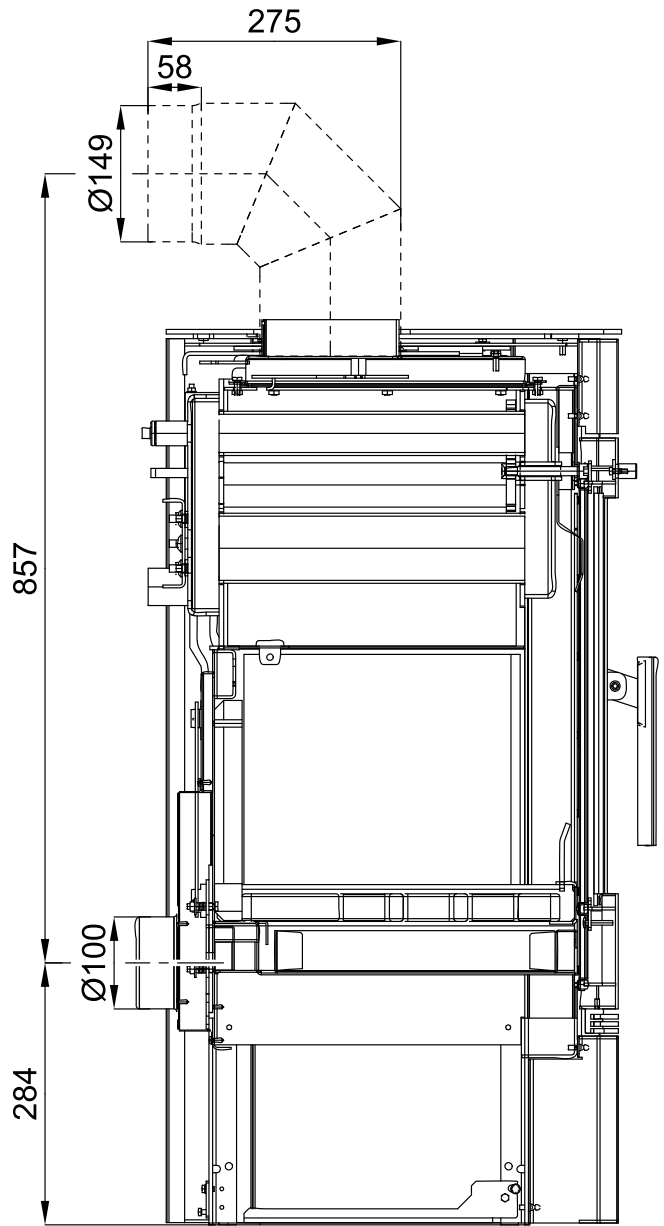
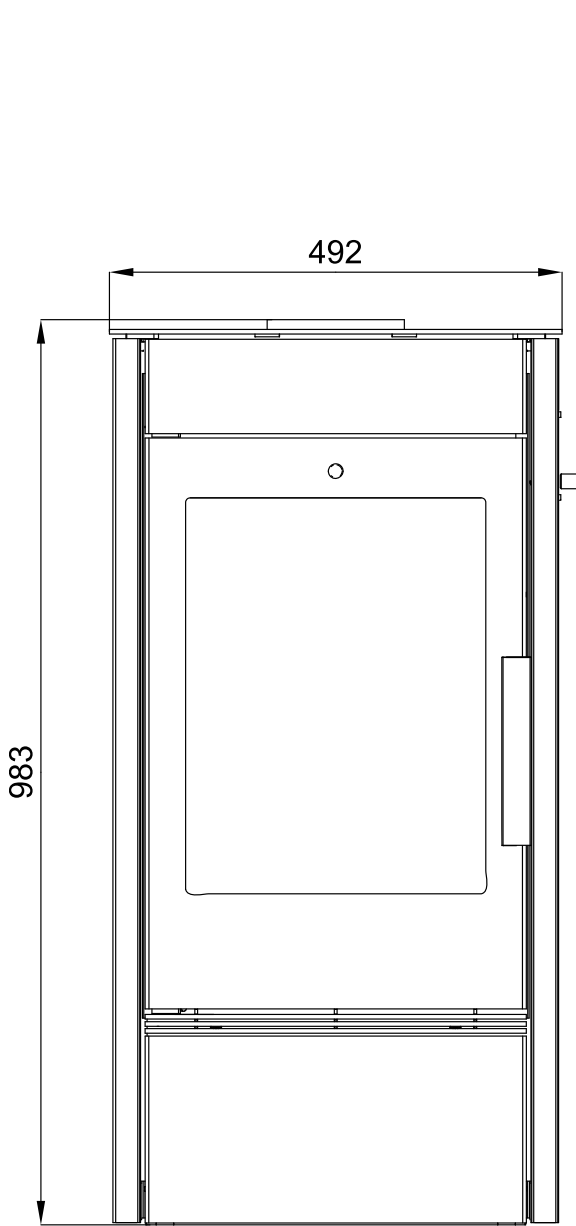

3. List of spare parts

3.1. Overall scheme of the model

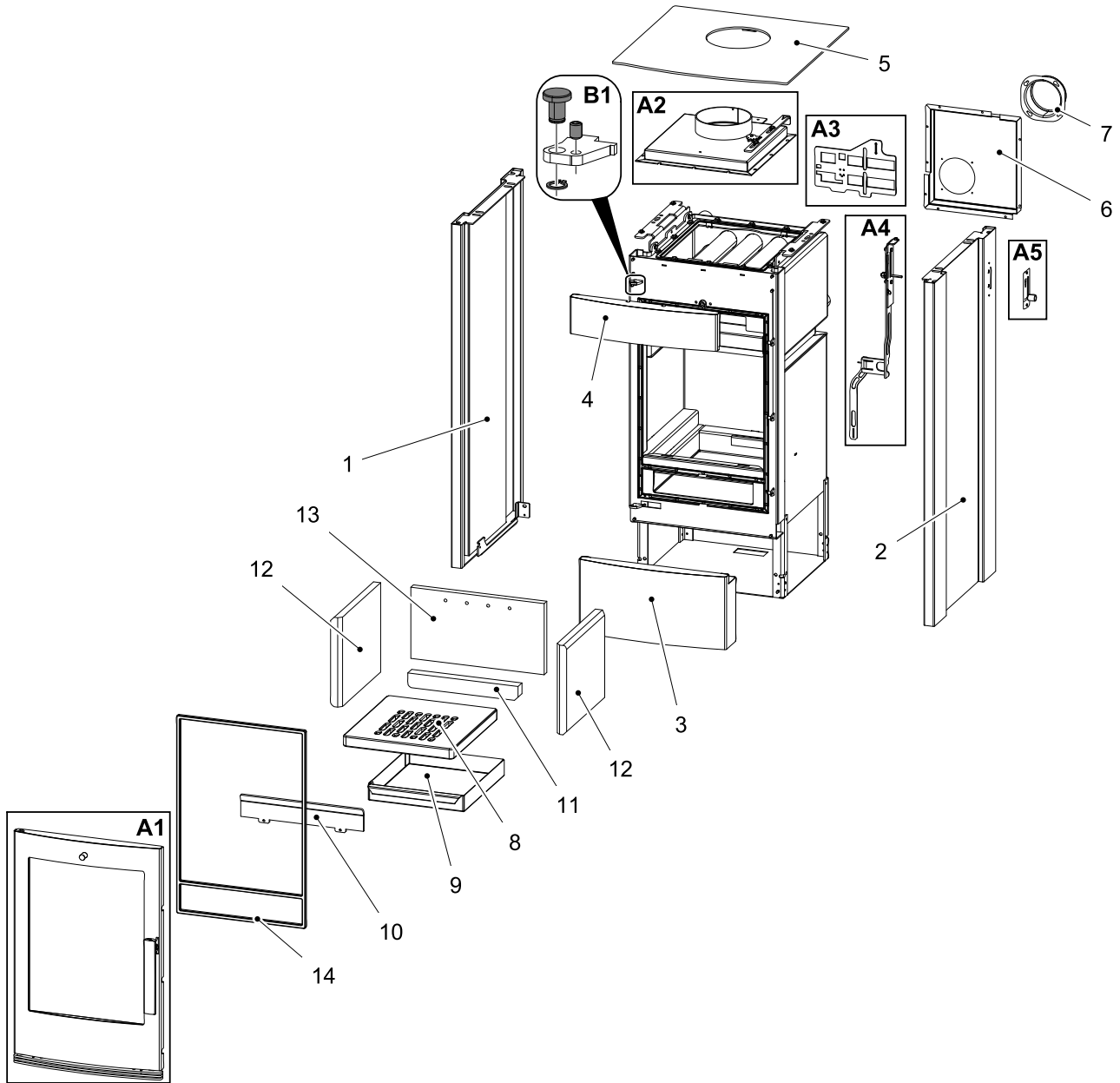

Item	Name	Quantity	Number of goods
Overall scheme of the model			
A1	Fire-box door (complete)/black-silver	1 piece	0434515005300
A1	Fire-box door (complete)/anthracite-silver	1 piece	0434515015300
A2	Lid (complete)/black	1 piece	0434515015095
A2	Lid (complete)/anthracite	1 piece	0434515115095
A3	Sliding valve (complete)/black	1 piece	0434617005027
A3	Sliding valve (complete)/anthracite	1 piece	0434617006027

A4	Control (complete)/Easycontrol	1 piece	0434518005060
A5	Controller (complete)	1 piece	0434615005005
B1	Hinge connecting material — set	1 piece	0434515005128
1	Lateral cover — left/black	1 piece	0434516025110
1	Lateral cover — left/anthracite	1 piece	0434516026110
2	Lateral cover — right/black	1 piece	0434516025100
2	Lateral cover — right/anthracite	1 piece	0434516026100
3	Lower cover/black	1 piece	0434515015146
3	Lower cover/anthracite	1 piece	0434515016146
4	Upper cover/black	1 piece	0434515115145
4	Upper cover/anthracite	1 piece	0434515116145
5	Top cover/black	1 piece	0434516025800
5	Top cover/anthracite	1 piece	0434516025800
6	Rear cover	1 piece	0434517005000
7	External air input (Ø100)	1 piece	0088500050008
8	Grate/lackfire	1 piece	0434515005053
9	Ashpan	1 piece	0434515005030
10	Protection	1 piece	0434515005040
11	Refractory lining — lower (30x40x310)	1 piece	0434617005552
12	Refractory lining — right+left (30x250x300)	2 piece	0434617005554
13	Refractory lining — rear (30x199x375)	1 piece	0434617005551
14	Door sealing cord 10 mm	2500 mm	0040300100005

3.2. Detail A1

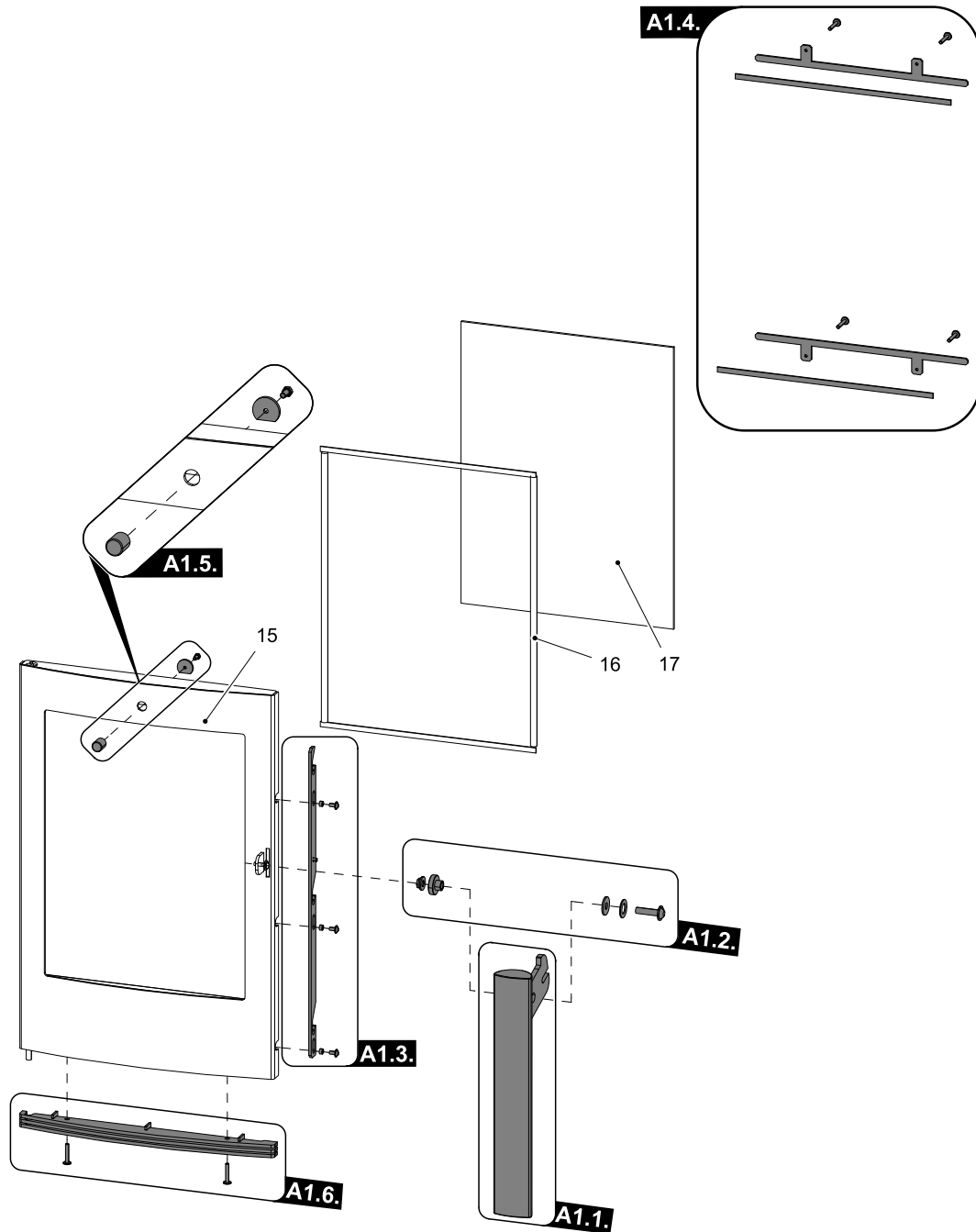

Item	Name	Quantity	Number of goods
Detail A1			
A1.1.	Fire-box door lever lock (complete)	1 piece	0429415005318
A1.2.	Handle connecting material — set	1 piece	0434615505002
A1.3.	Closing mechanism drawbar — set	1 piece	0434615005321
A1.4.	Glass holder — set/black	1 piece	0434615005330
A1.4.	Glass holder — set/antracite	1 piece	0434615006330
A1.5.	Cleaning cover — set/black	1 piece	0434515505005
A1.5.	Cleaning cover — set/antracite	1 piece	0434515405005

A1.6.	Shutter/silver — set	1 piece	0434515005315
15	Fire-box door (welded part)/black	1 piece	0434515005200
15	Fire-box door (welded part)/anthracite	1 piece	0434515006200
16	Glass sealing cord 10x4 mm	1660 mm	0040210040005
17	Refractory glass (345x455)	1 piece	0434515005304

3.3. Detail A2, A3, A4, A5

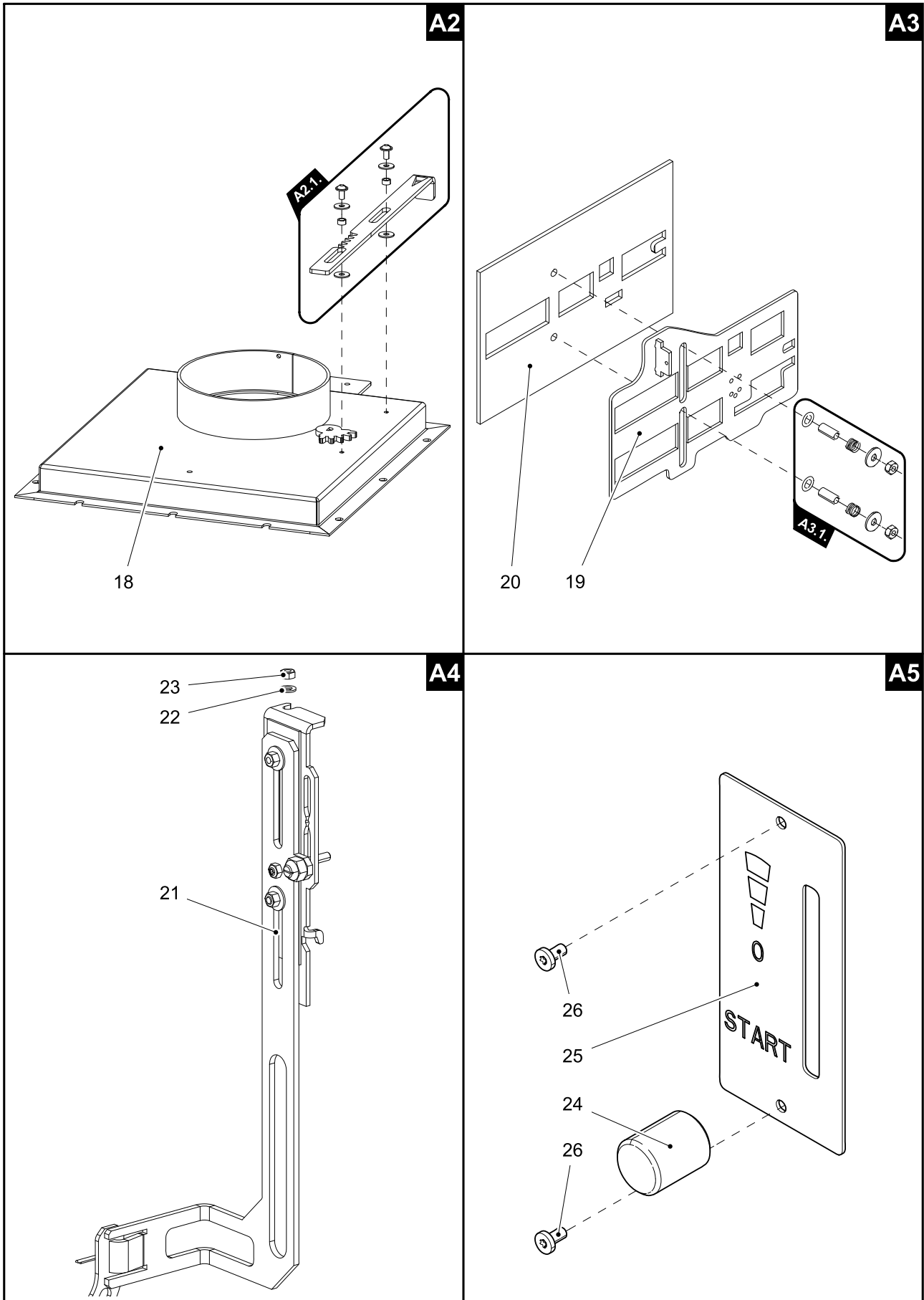

Detail A2			
Item	Name	Quantity	Number of goods
A2.1.	Flap drawbar/black — set	1 piece	0434515005088
A2.1.	Flap drawbar/anthracite — set	1 piece	0434515006088
18	Lid/black	1 piece	0434515015085
18	Lid/anthracite	1 piece	0434515016085
Detail A3			
Item	Name	Quantity	Number of goods
A3.1.	Sliding valve connecting material — set	1 piece	0434615005003
19	Sliding valve/black	1 piece	0434617007027
19	Sliding valve/anthracite	1 piece	0434617008027
20	Sliding valve sealing	1 piece	0434517005052
Detail A4			
Item	Name	Quantity	Number of goods
21	Control/Easycontrol	1 piece	0434518005060
22	Washer 5.3 DIN 125A	1 piece	-
23	Nut M5 DIN 980V	1 piece	-
Detail A5			
Item	Name	Quantity	Number of goods
24	Controller	1 piece	0420915005625
25	Controller label	1 piece	0429415005171
26	Screw M3x10 BN 9524	2 piece	0030400300105

4. Dimensioned diagram

4.1. Connection of the exchanger

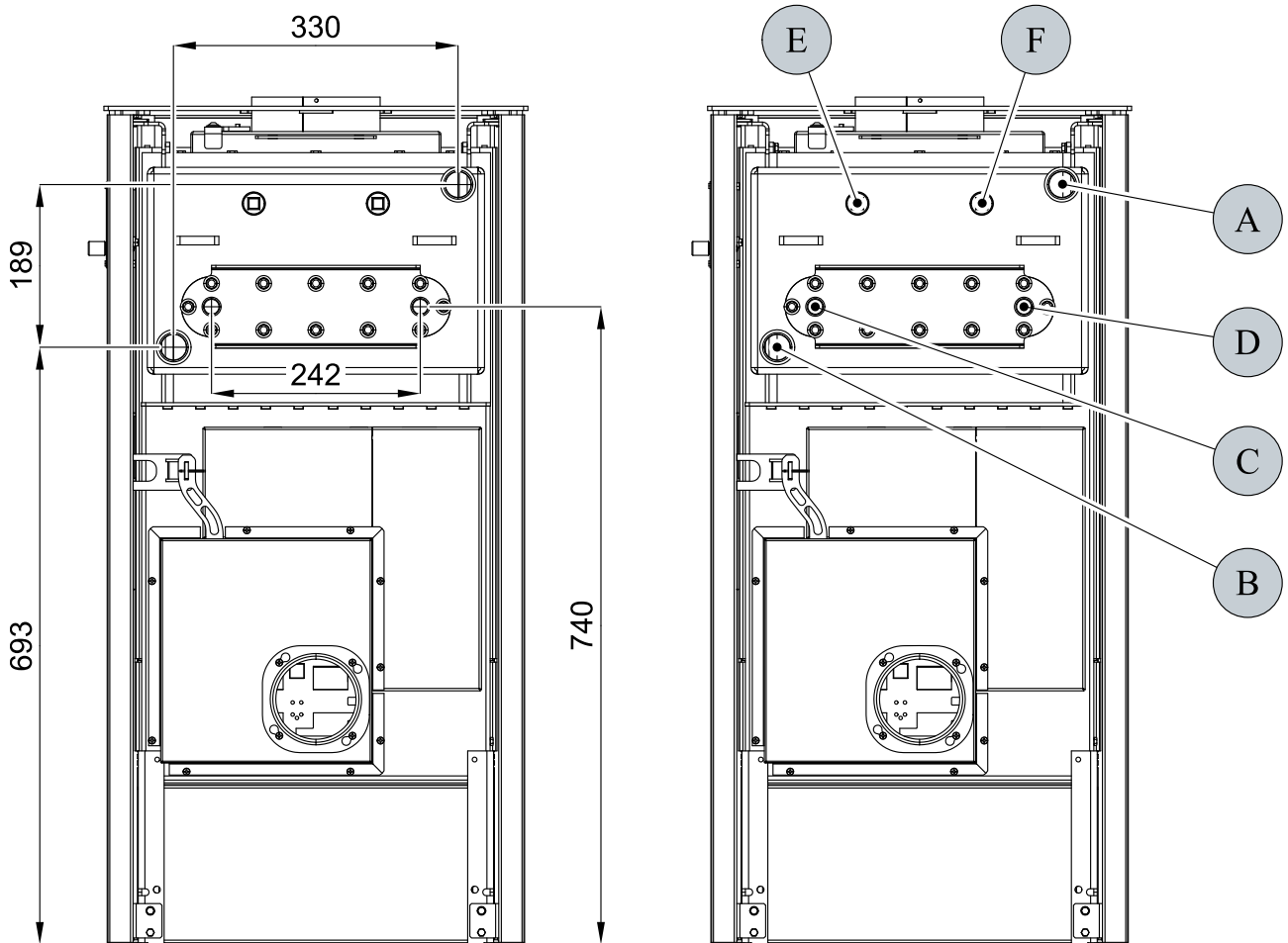

Dimensioned diagram

GB

Item	Name
A	Forward flow connection (inside thread G1")
B	Reverse flow connection (inside thread G1")
C	Intake of cooling liquid (outside thread G1/2")
D	Outlet of cooling liquid (outside thread G1/2")
E	Hole for thermostatic sensor cup (inside thread G1/2")/cooling loop
F	Hole for thermostatic sensor cup (inside thread G1/2")/circulation pump

5. Easy control

Control of all three air inputs - primary, secondary, tertiary - by means of one sole controller.

1. The controller is in the position intended for ignition (fig. A). All three air inputs are open (primary, secondary, tertiary).
2. The controller is in the position intended for burning of the stove after ignition (fig. B). Two air inputs are opened only (secondary, tertiary).
3. The controller is in the position designed to close air inputs (Fig. C). No input is open (primary, secondary, tertiary). This position is used only when the stove is out of operation, after finishing the heating process.



WARNING

Air inputs may not be closed during the heating operation (Fig. C)! In an extreme case, there can occur an explosion in the stove followed by breaking of glass, blowing up of cinders across the room and breaking out of the fire.

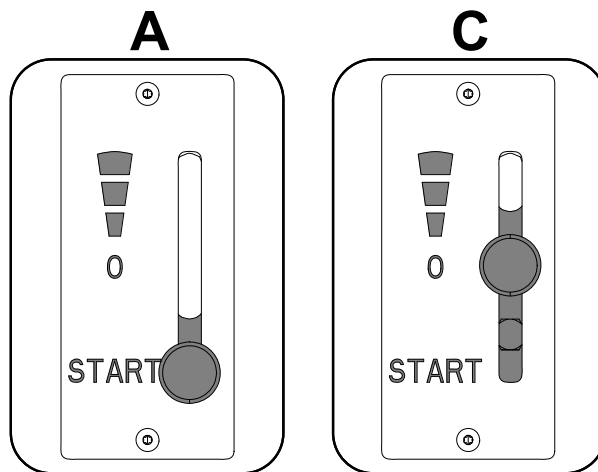

B

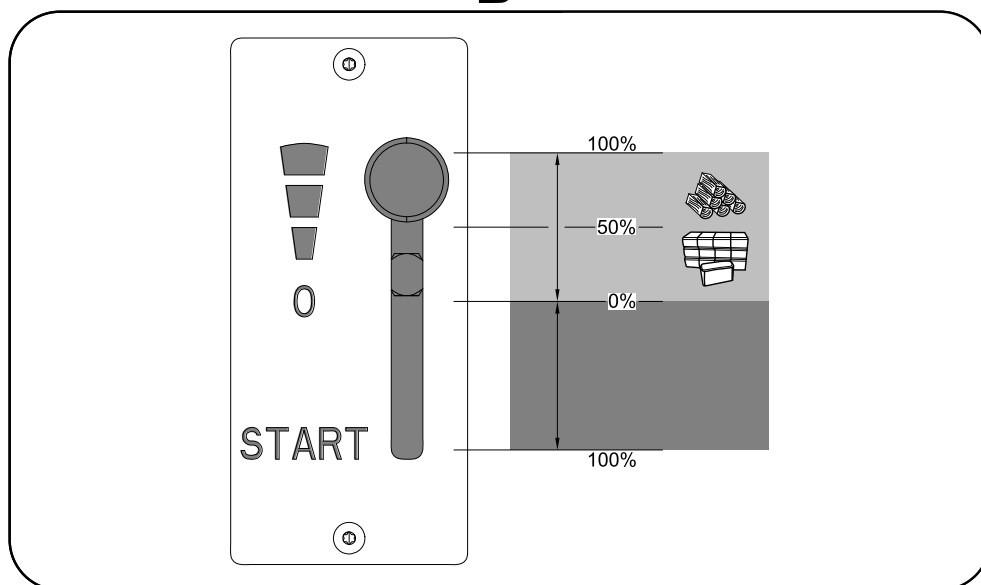

6. Ignition flap



IMPORTANT

When lighting the stove or if the stove has a weak draft, pull out the ignition flap controller to Position 0 (Fig. A). In this position, the ignition flap is open. During the heating, push the ignition flap controller to Position 1 (Fig. B). In this position, the ignition flap is closed.



Note

Keep in mind that heating efficiency is significantly reduced, the fuel consumption increases and emission parameters deteriorate when heating with the kindling vent open for a prolonged period of time!

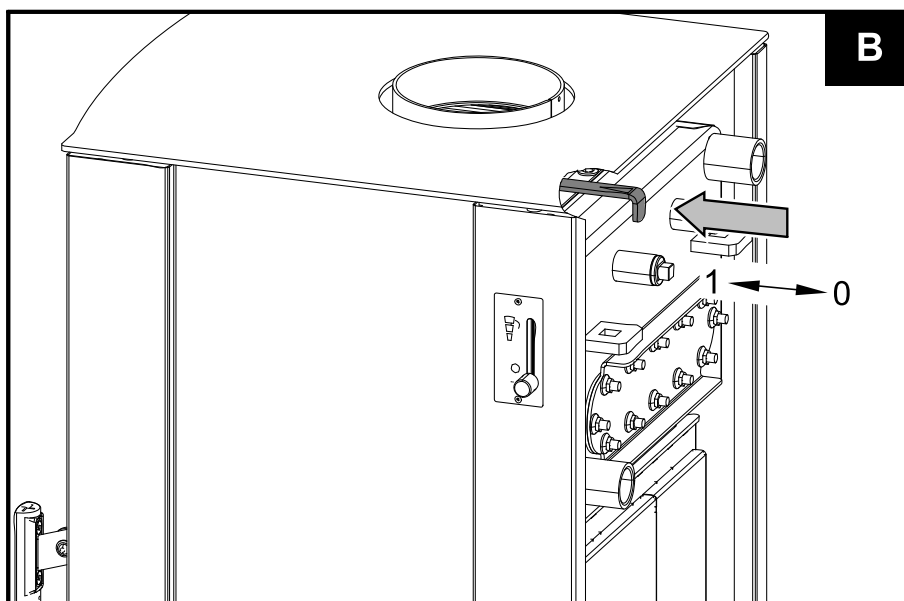
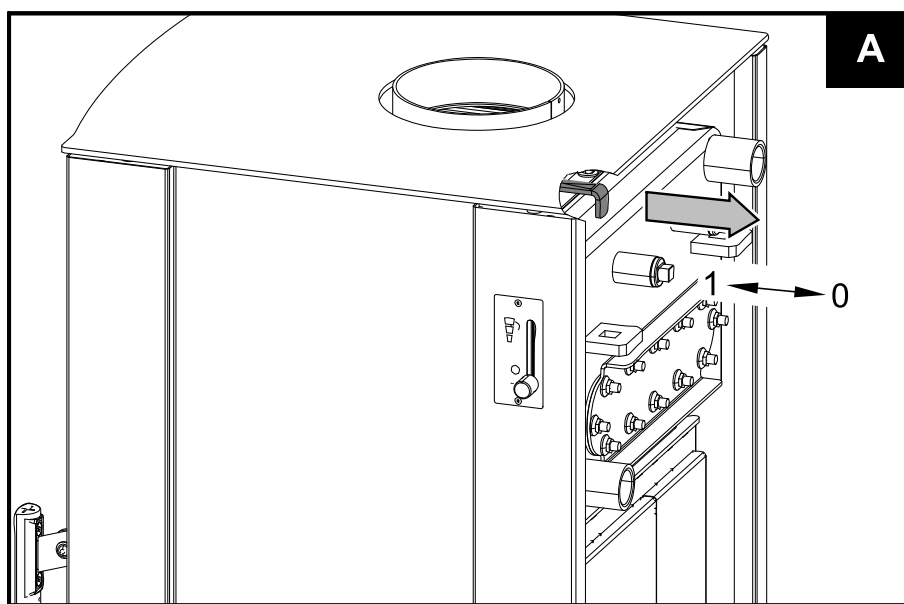

7. Installation of the coolant loop



IMPORTANT

Coolant loop not included in the scope of the delivery.

Installation of the coolant loop

GB

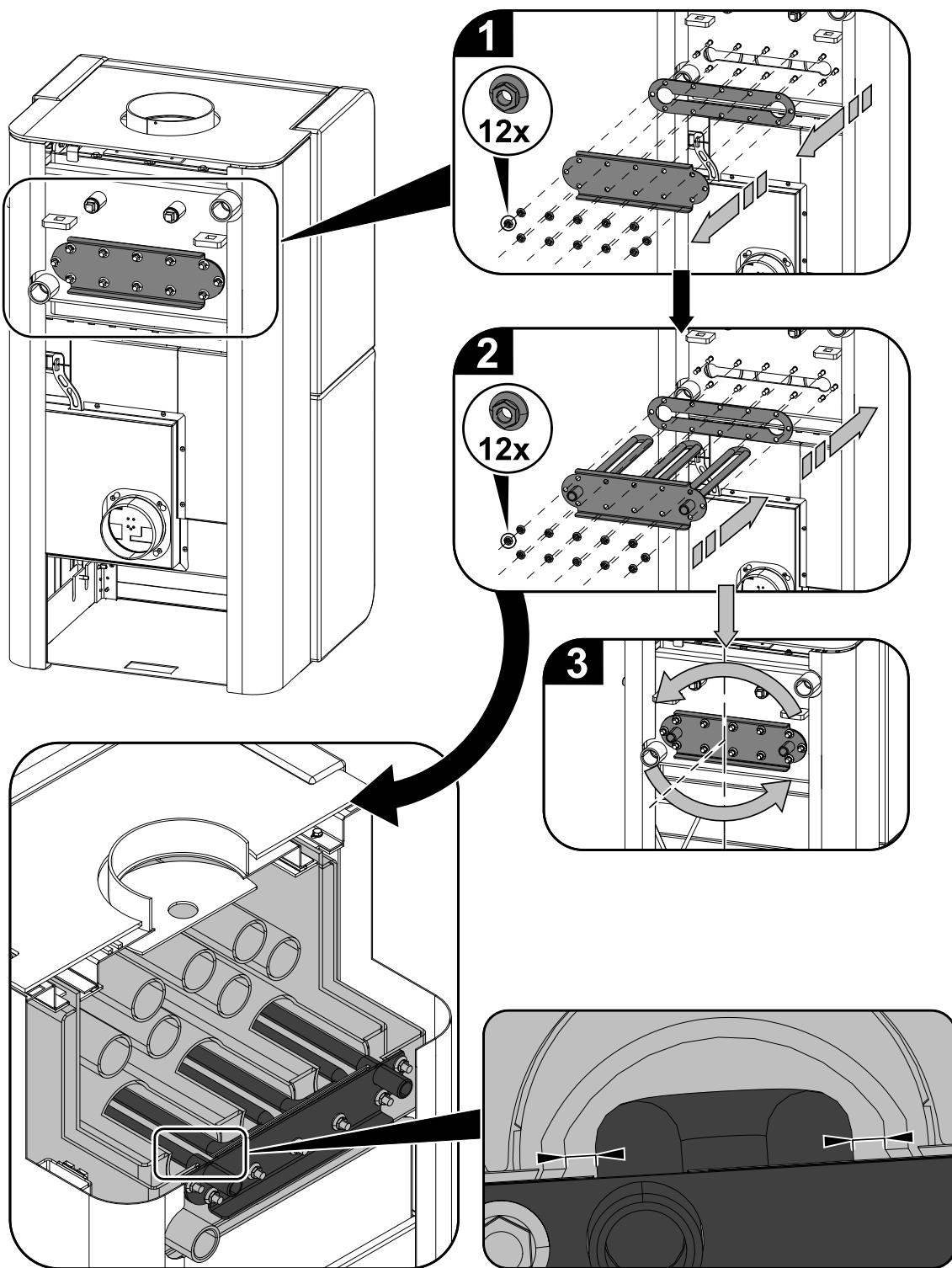

8. Instructions for cleaning of the exchanger



IMPORTANT

It is recommended to perform the cleaning by wiping blade (item 4, fig. 5) 1x in a week at least, or more often, depending on the manner of operation

1. Preparation and mounting of the cleaning drawbar.

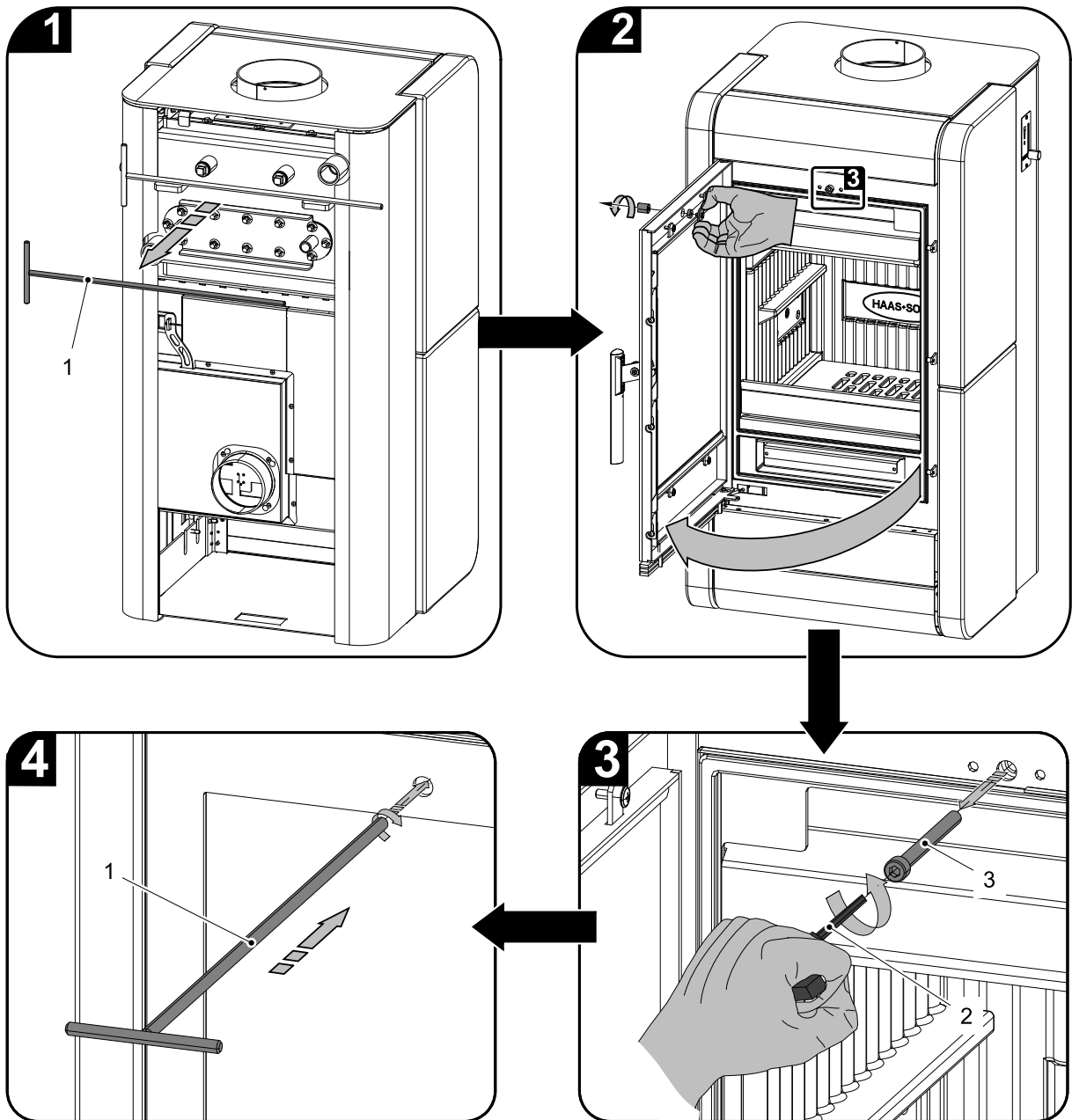

2. Proper cleaning and arrestment of the cleaning board.



IMPORTANT

Once the clearing is terminated, arrest the wiping blade always (fig. 5a). Do not leave the wiping blade above a flame (fig. 5b).

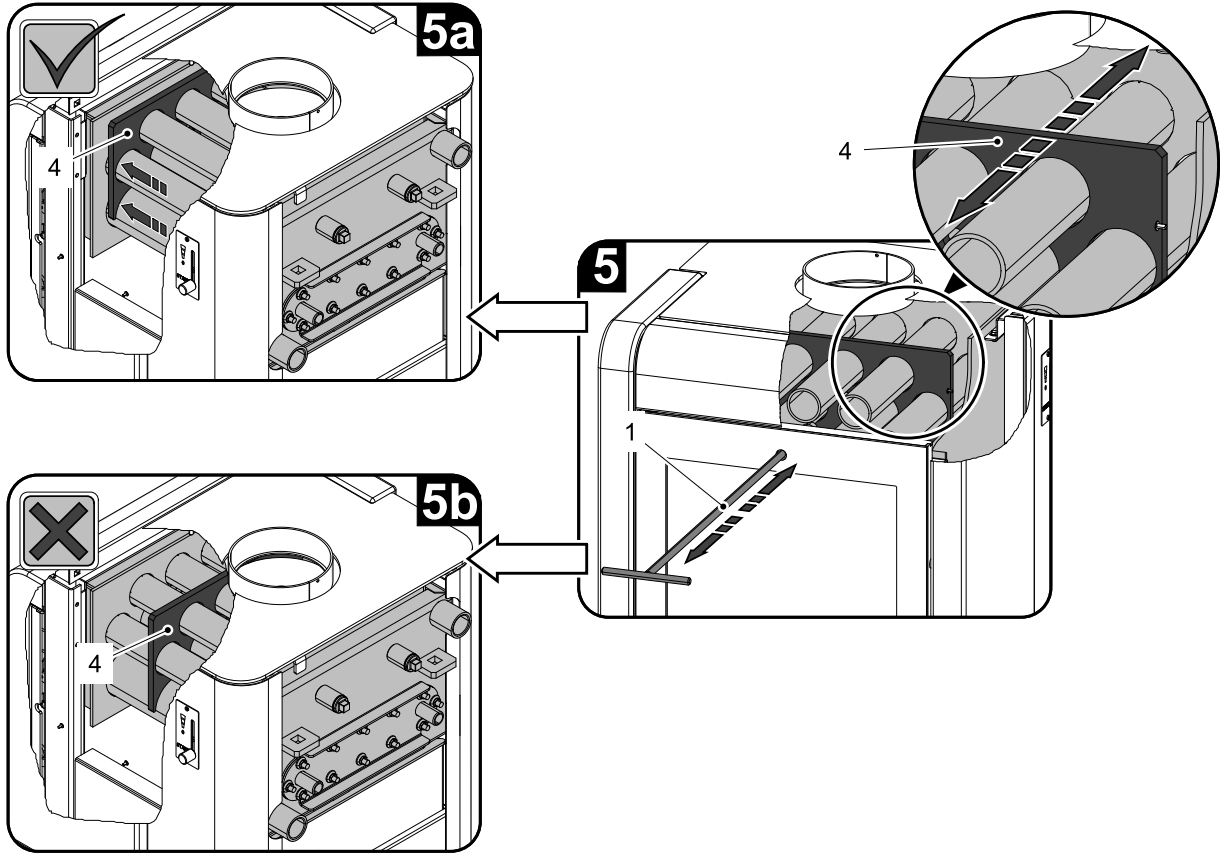

GB

Item	Name	Number of the spare part
1	Drawbar of the cleaning/black	0433317005063
2	Allen wrench 8mm (forms part of the delivery)	9001700080005
3	Screw M10x80 (DIN 912)	0030031000805
4	Wiping blade	—

